



*Paving Intelligence into
Safety, Security & Mobility*



XCam-TD™

Traffic Data Collection
Video Sensor

Citilog's XCam-TD™ is a real-time video-sensor enclosed in a rugged elegant housing for Traffic Data Collection on roadways.

The XCam-TD™ video-sensor is designed to replace or expand upon in-road magnetic loop detectors with a Traffic Data Collection solution featuring an advanced video-based sensor.

XCam-TD™ eliminates constraints imposed by embedded loops. Power and communications infrastructure are also not an issue since XCam-TD™ provides built-in low power consumption and wireless communications.

XCam-TD™ components (particularly the CMOS sensor) have been specifically designed to ensure durability of the sensor while optimizing performance of the video-detection algorithm. The XCam-TD™'s detection algorithm is flexible and adaptable to changing environmental conditions (night or day, sun or rain) to maximize traffic monitoring capabilities.

The XCam-TD™ is a low cost sensor that makes the most of existing infrastructure and its components resulting in a quick return on investment and an excellent cost/benefit ratio. The XCam-TD™ video sensor allows to more cost effectively replace loop-based detection. It also enables low-cost seamless expansion of Traffic Data Collection capabilities and monitoring reach for roadways.

System setup and modification of detection zones are performed within a few minutes, with a friendly graphical user interface (GUI) via a laptop computer.

Detection zones are easily associated with loop detector outputs for a direct loop replacement.

Fail-safe functionality allow for true 24/7 operation.

The XCam-TD™ communicates with any field equipment or through standard or customized advanced communications protocols (serial or Ethernet).



KEY CAPABILITIES

- Accurate traffic data collection.
- Embedded loop replacement.
- Low power consumption and wireless communications for easy deployment and integration.
- Video streaming for monitoring.
- Seamless communication with field equipment or controllers and integration into existing traffic management systems.
- Improves road safety and mobility thus reducing environmental impacts from traffic congestion and delays.
- Local traffic data storage (up to 30 days) for data pulling and on-demand communications.

KEY BENEFITS

- Low cost and seamless deployment of data collection points.
- Fast ROI for above-ground detection compared to traditional road-embedded sensors.
- Reduce the negative economic, social and environmental impact from traffic congestion.
- Improve infrastructure efficiency.



The XCam-TD™ can provide video streaming permitting remote monitoring of data collection points and monitoring via the Traffic Management Center. Configuration or maintenance operations can also be performed remotely for greater efficiency and a lower cost of operation and maintenance.

The XCam-TD™ is delivered with a mounting bracket, extension pole and connection block. This allows the XCam-TD™ to be installed in the field without opening the video sensor housing, thus extending its life and avoiding trouble shooting in the field. Its capabilities go beyond typical requirements of traffic data collection sensors to ensure durability.

The extension pole can be adjusted in length and mounted either horizontally or vertically to fit the physical requirements of any site.

DETECTION HIGHLIGHTS

- High performance trajectory and tracking-based traffic data collection.
- High efficiency algorithm with comprehensive filters for all weather and lighting conditions.
- Easy setup, configuration and maintenance.
- Video streaming capability.

APPLICATIONS

- Embedded loop replacement.
- Speed, Volume, Occupancy.
- Vehicle Classification

The XCam-TD™ provides a cost-effective, easy-to-install and field-proven solution for traffic data collection on roadways.

Technical Specifications

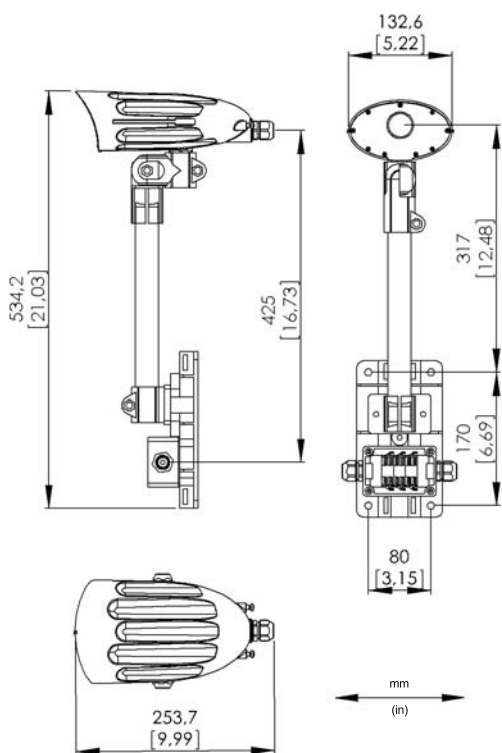

Sensor

- 1/4" VGA CMOS sensor.
- Minimum illumination 0.04 lux. @ f/1.2.
- Anti-blooming, zero smearing.
- Signal to Noise ratio: >50dB.

Housing

- IP67 Injection molded polycarbonate housing.
- Sun shield for hot climate and direct sun exposure.
- Size: 132 x 254 x 124 mm.

Hardware

- Power Supply: +12/24V AC/DC.
- Power consumption: < 3W.
- -34°C / +74°C.
- Humidity: 0 to 95% RH, non condensing.
- Weight: 600 g.

Communications

- Wireless module (GPRS, ISM).
- Output: Ethernet or RS485.



www.citilog.com

NORTH AMERICA

2 Bala Plaza, Suite 300
Bala Cynwyd, PA 19004 - USA
Tél: +1 (215) 609-4945
Fax: +1 (484) 873-2292
citilogusa@citilog.com

EUROPE, MEA & AFRICA

19/21, rue du 8 mai 1945
94110 Arcueil - France
Tél: +33 1 41 24 34 54
Fax: +33 1 41 24 34 99
citilog@citilog.com

SPAIN, PORTUGAL & SOUTH AMERICA

C./Marina Baixa 3, Esc.1 Pta.2
E46015 Valencia - Spain
Tél: +34 667 659 063
Fax: +33 1 41 24 34 99
espana@citilog.com

ASIA PACIFIC

35/F Central Plaza
18 Harbour Road
Wanchai Hong Kong
Tél: +852 2593 1500
Fax: +852 2593 1222
citilog@citilog.com

Latest Hardware specifications available upon request