



04/2020

H18-2



①

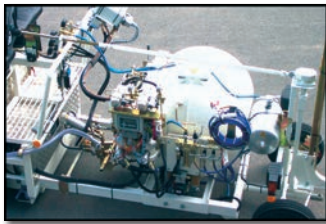

②



③

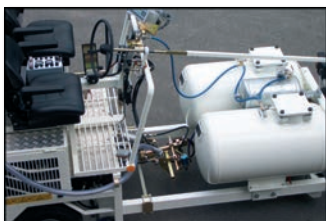

④

A compact, narrow and maneuverable machine with medium-sized capacities.

- Hydraulic drive with wheel motor with infinitely variable speed adjustment. Hydraulic multi disk parking brake.
- Cooling system with automatic adaption of ventilator speed to ambient temperature and machine load (noise reduction at normal machine load and higher cooling performance at extreme machine load).
- Inlet of whole cooling air from upper side of the machine - far away from spray mist.
- One pressurised glass bead tank.
- Cockpit with all operating elements laterally adjustable without the need to install guides.
- Free view during center- and edge line markings.
- Individual application units (exchangeable container) or exchange of front chassis incl. application unit at low effort by quick opening device systems and modular design principle.
- Engine compartment easily accessible for service work.
- Excellent panoramic view, also when driving backward.
- Exhaust pipe is under the machine and exhaust outlet is adjustable depending on the application.
- Fold-out ladder on the seat support.

- ① H18 bellow pump system (460 l) with Spotflex® system, M98: 2 and electrical glass bead dispenser
- ② Cold paints Airless, with pump, 2 paint spray- and 2 glass bead guns, 450 l
- ③ MultiDotLine® Universal-Extruder, 30cm
- ④ Cold paints Airspray (low-pressure method), with paint spray- and bead gun, 2 x 225 l

Technical Data

4-cylinder 2400 cm³, Kubota Turbo diesel engine, water-cooled

Version I:

Non label (corresponds to EU Stage IIIA resp. (US) EPA Tier 4 Interim) 44,0 kW at 2700 rpm

Version II:

low-emission EU Stage V resp. (US) EPA Tier 4 with diesel oxidation catalyst (DOC) and Diesel Particulate Filter (DPF) 48,6 kW at 2700 rpm

Fuel tank: 75 l in safety zone in front of rear axle

Hydraulic oil tank: 65 l

Air output, alternatively: 1300 - 2200 l/min at 7,5 bar; compressed-air cooler

Drive unit:

- infinitely variable hydraulic drive
- acts simultaneously as service brake
- speed range: 0 – 20,0 km/h

Power-take-offs for up to 3 hydraulic pumps, for several drives like material metering pumps, agitators etc.

Pressurised glass bead container: 170 l (max. 0,8 bar)

Dimensions (L x W x H mm): 4260 up 5600 x 1260 x 2300 (dependent on equipment)

Weight, equipped: approx. 2000 – 2600 kg approx. 4409 – 5732 lbs

Total admissible weight: approx. 4000 kg approx. 8818 lbs

Cold paints

Containers up to 540 l*

540 l pressure container is suitable for equipment with universal pump (up to 18 l/min pump capacity), can be operated also unpressurised.

Universal pump suitable for high-pressure spraying method (Airless) and low-pressure spraying method (atomising-air-spraying method/Airspray).

Using the Airspray method the pump is also suitable for nonairless paints with or without mixed-in glass beads. (see information n° 374 and 382)

Marking with control governed by travelled distance (AMAKOS®) can be used under certain circumstances: Constant line thickness irrespective of marking speed as well as manual adjustments are selectable. (see information n° 396)

2-component cold plastics

Containers sprayable cold plastics: up to 540 l *

cold plastics: up to 540 l *

460 l and 540 l pressure container (only 98:2) are suitable for equipment with universal pump (up to 18 l/min pump capacity), can be operated also unpressurised.

Sprayable cold plastics 1:1 and 98:2

Universal pump suitable for high-pressure spraying method (Airless) and low-pressure spraying method (atomising-air-spraying method/Airspray). Using the Airspray method the pump is also suitable for nonairless sprayable cold plastics with or without mixed-in glass.

(see information n° 374, 387)

Extrud. cold plastics 1:1 and 98:2 Plain, structured (agglomerate), and Spotflex® (bellow pump or pressurised container system) as well as profiled markings (screed box system) up to 15 mm line thickness (depending on material).

(see information n° 384, 385)

Thermoplastics

Containers extrudable thermoplastics: up to 320 l * heated by LPG or diesel oil.

Open thermoplastic screed boxes with oil jacket and LPG- or diesel oil heating, incl. exchangeable shutters for line widths from 10-50 cm as well as equipments for profiled markings.

(see information n° 279)

Thermoplastic extruder for single-, double- and triple lines of variable width, for simultaneous application of continuous / interrupted lines as well as for profiled markings with many different profiles (Universal extruder MultiDotLine®). Due to its modular design, existing extruders can be modified at any time in order to execute different plain- and profiled markings.

(see information n° 279,343,430)

Connection possibility for screed box and extruder on both sides.

Sprayable thermoplastics

Containers sprayable thermoplastics: up to 320 l * heated by LPG or diesel oil.

Gun support for max. two spray guns left or right (dependent on material and equipment).

Heat transfer oil circulating pump and heat exchanger for heating of atomiser air for improvement of material sprayability.

Pressurised containers: In case of an air pressure drop an emergency valve automatically closes.

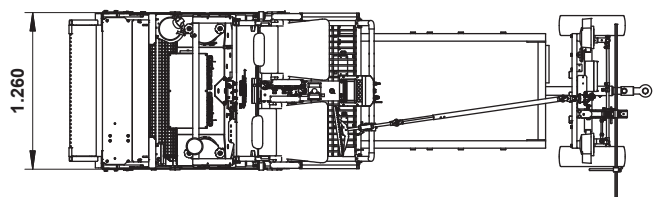
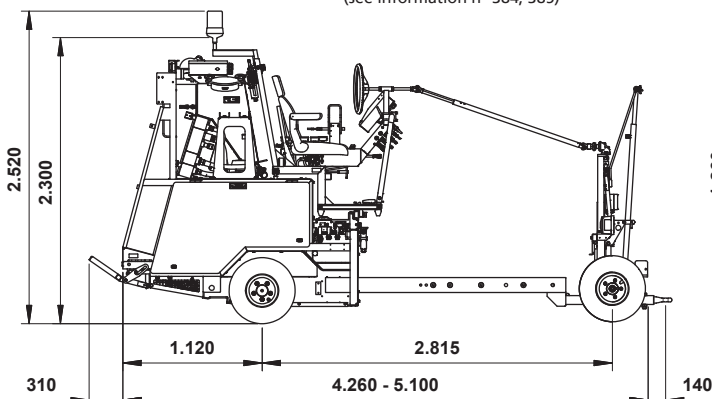

*Customised sizes upon request